

Name: _____

Number: _____

Department of Mechanical and Aerospace Engineering

MAE334 - Introduction to Instrumentation and Computers

Final Examination

December 12, 2003

Closed Book and Notes

1. Be sure to fill in your name and 8 digit person number (starting from the left and with no gaps or hyphens) on side two of the scoring sheet and also on this questioner.
2. Be sure to fill in circle number 1 under the "Grade or Education" box on side two of the scoring sheet. This is your exam number. There are 4 different exams!
3. For each question, choose the best answer and place a mark corresponding to that answer on the machine scoring form.
4. All questions are weighted equally.
5. The Student-t distribution table is on the last page of the exam.

Failure to correctly complete steps 1 and 2 above will most likely result in a grade of ZERO!

Reminder:

- Lab #1 Limitations on A/D Conversion
- Lab #2 Thermocouple, Static and Dynamic Calibration
- Lab #3 Conversion of Work into Heat
- Lab #4 Pressure Transducer, Static and Dynamic Calibration
- Lab #5 Filters, Transfer Functions and Spectral Analysis

- 1) In Microsoft Excel 100 evenly spaced time axis values could be produced in column A by inserting, =A1+1, into cell A2 and copying the formula into cells A3:A100?
 - a) True
 - b) False
- 2) In Microsoft Excel array functions like LINEST are entered using Shift+Enter as opposed to just Enter after the function has been typed in.
 - a) True
 - b) False
- 3) In Microsoft Excel to obtain the student-t distribution table estimate for, $t_{10, 95\%}$, you would use the formula =TINV(95%,10).
 - a) True
 - b) False
- 4) In Microsoft Excel the simplest way to plot a logarithmically scaled x axis is to compute $\log(x)$ and then plot the data.
 - a) True
 - b) False
- 5) When aliasing of a signal occurs, the sampled signal will appear to have a frequency content which is _____ that of the true signal.
 - a) greater than
 - b) less than
- 6) If the Nyquist criterion is satisfied if you sample an input signal at a sampling frequency which is half the highest frequency in the signal.
 - a) True
 - b) False
- 7) To adequately resolve a the shape of an input signal waveform 10-15 points per waveform cycle are needed.
 - a) True
 - b) False
- 8) Fortunately if an input signal exceeds the input range of your ADC the sample statistics will not be altered.
 - a) True
 - b) False
- 9) The ADC hardware and software used in our lab was supplied by National Semiconductor.
 - a) True
 - b) False
- 10) The slope of the static calibration curve is known as the:
 - a) Response function
 - b) Time constant
 - c) Static sensitivity
 - d) None of the above

- 11) The thermocouple is considered a first order instrument because
- it has only one sensing element.
 - its static behavior is described by a first order differential equation.
 - its dynamic behavior is described by a first order differential equation.
 - both (a) and (c) are correct.
 - both (b) and (c) are correct.
- 12) A thermistor
- requires a constant cold junction to remain calibrated.
 - changes resistance in proportion to changes in temperature.
 - outputs a small voltage which is proportional to the temperature.
 - requires a voltage source to function.
 - both b) and d) are correct
- 13) The slope of the linearized error function, $\Gamma(t)$, of a 1st order system is
- τ
 - $1/\tau$
 - $-1/\tau$
 - $-t/\tau$
- 14) Which of the following does not represent the dynamic characteristics of the pressure transducer system used in lab 4?
- Behaves like 2nd order system.
 - Its natural frequency (ω_n) is high.
 - It has an overdamped damping ratio (ξ)
 - It is a deflection rather than a null device.
- 15) If the pressure transducer's natural frequency, ω_n , is 150KHz what would you expect its maximum measurable pressure frequency to be?
- greater than ω_n
 - approximately equal to ω_n
 - less than ω_n
- 16) Given a resistor, R , and a capacitor, C . The relationship between the input signal, $F(t)$, and the output signal, $y(t)$, of a Butterworth low pass filter can be modeled with the equation
- $\frac{1}{2\pi RC} \dot{y}(t) + y(t) = F(t)$
 - $RC\dot{F}(t) + F(t) = y(t)$
 - $\frac{1}{RC} \dot{y}(t) + y(t) = F(t)$
 - $RC\dot{y}(t) + y(t) = F(t)$

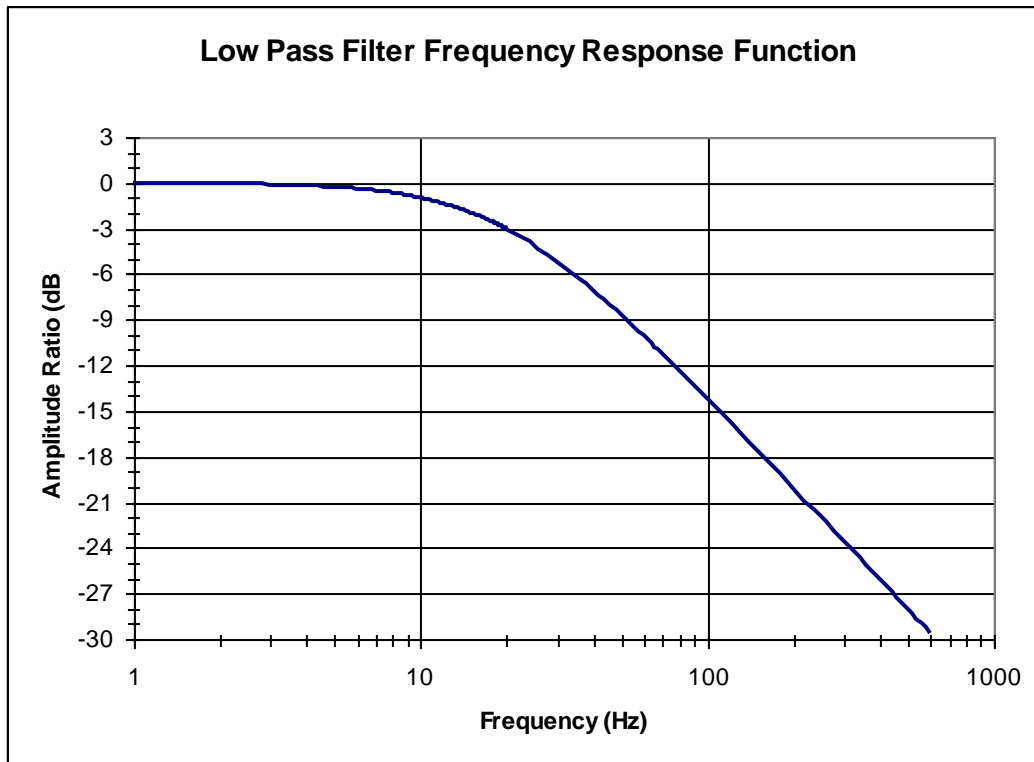

Figure 1. Low pass filter Magnitude Ratio versus Frequency plot.

- 17) The cut off frequency, f_c , of a filter with the response function plotted in Figure 1 is approximately
- 3 Hz
 - 10 Hz
 - 20 Hz
 - 600 Hz
- 18) A Bode plot is normalized so filters with different cutoff frequency, f_c , can be easily compared.
- True
 - False

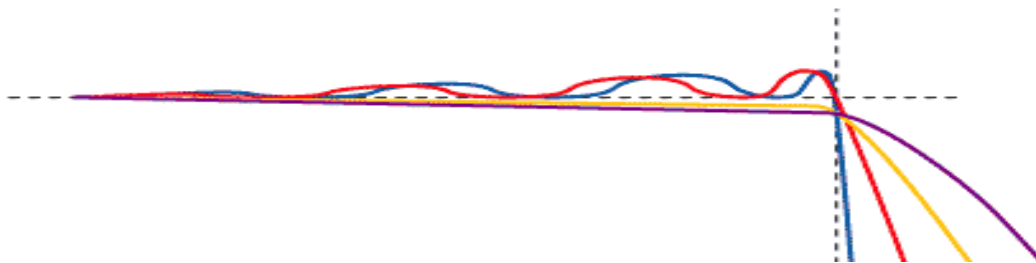

Figure 2. Low pass filter magnitude response in dB versus log of frequency of four different filter types, Bessel, Butterworth, Elliptic and Chebyshev, all with the same cut off frequency.

- 19) Of all the filter response characteristics plotted in Figure 2, the Elliptic filter is most likely to have the steepest magnitude roll off as the frequency increases.
- True
 - False

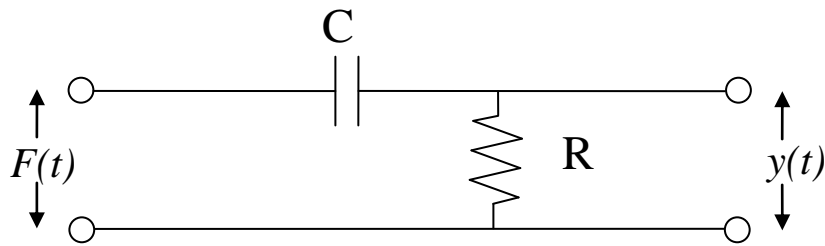

Figure 3. Single Pole Passive Filter Circuit

- 20) By combining 2 of the circuits drawn in Figure 3 in series the output, $y(t)$, can be correctly modeled as a second order system with respect to the input, $F(t)$?
- True
 - False
- 21) The single pole passive filter drawn in Figure 3 has a time constant, τ , of
- $\tau = RC$
 - $\tau = 1/RC$
 - $\tau = 2\pi/RC$
 - $\tau = 1/2\pi RC$
- 22) The filter circuit in Figure 3 is a single pole Butterworth high pass filter.
- True
 - False
- 23) To fabricate a single pole Butterworth low pass filter to help reduce 60 Hertz noise from a low frequency signal you could use these components? $1 \mu\text{F} = 10^{-6}$ Farad, $1 \text{nFarad} = 10^{-9}$ Farad, $1 \text{pF} = 10^{-12}$ Farad, $1 \text{K}\Omega = 1000 \Omega$, $1 \text{M}\Omega = 10^6 \Omega$
- a $100 \text{K}\Omega$ resistor and a 200nF capacitor
 - a $105 \text{K}\Omega$ resistor and a $1 \mu\text{F}$ capacitor
 - a $10 \text{M}\Omega$ resistor and a 265pF capacitor
- 24) Which low pass filter type has a linear phase shift or a constant time delay between the input and output signals?
- Bessel
 - Butterworth
 - Chebyshev
 - Elliptic
- 25) The transfer function of a first order sensor, like the thermocouple tested in lab 2, is a complex valued function?
- true
 - false

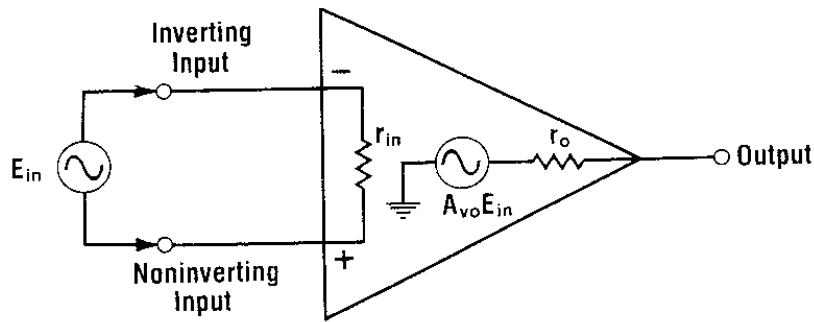

Figure 4. The equivalent circuit of an ideal operational amplifier.

26) For the ideal operational amplifier in Figure 4

- a) $r_{in} = \infty, r_o = \infty, A_{vo} = \infty$
- b) $r_{in} = \infty, r_o = 0, A_{vo} = \infty$
- c) $r_{in} = \infty, r_o = 0, A_{vo} = 1$
- d) $r_{in} = 0, r_o = \infty, A_{vo} = \infty$
- e) $r_{in} = 0, r_o = 0, A_{vo} = \infty$

27) For a real operational amplifier similar to that pictured in Figure 4 the bandwidth is infinite.

- a) true
- b) false

28) For a real operational amplifier similar to that pictured in Figure 4 the output is perfectly zero if the difference between the + and - inputs is zero.

- a) true
- b) false

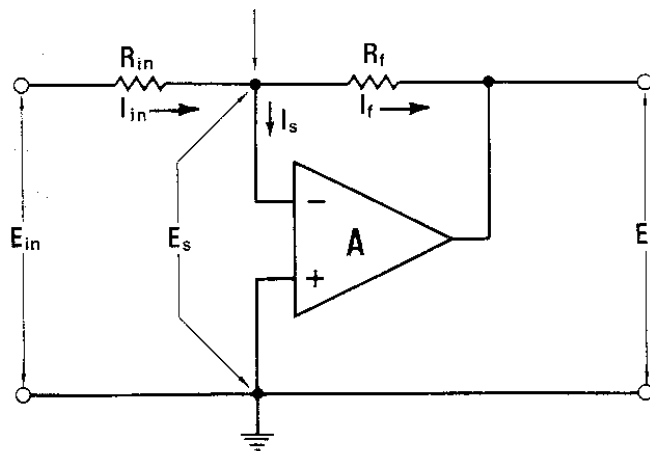

Figure 5. Basic Operational Amplifier Circuit 1

29) For the basic operational amplifier circuit in Figure 5,

- a) $I_{in} = I_f, E_{in} = E_s, I_s = 0, \text{Gain} = -R_f/R_{in}$
- b) $I_{in} = I_f, E_{in} = I_{in}R_{in}, \text{Gain} = R_f/R_{in}$
- c) $I_{in} \neq I_f, E_s = 0, I_s = 0, \text{Gain} = -R_f/R_{in}$
- d) $I_{in} = E_{in}/R_{in}, E_s = 0, I_s = 0, \text{Gain} = -R_f/R_{in}$

Use the following answers for the next 5 questions

- a) Integrator
- b) Differential Amplifier
- c) Differentiator
- d) Non-inverting Amplifier
- e) Inverting Amplifier

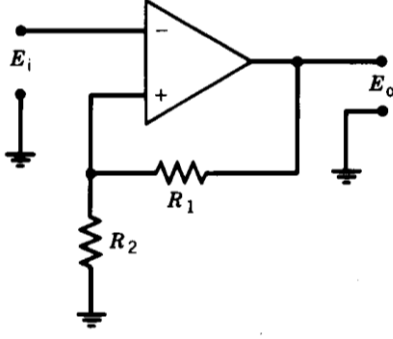
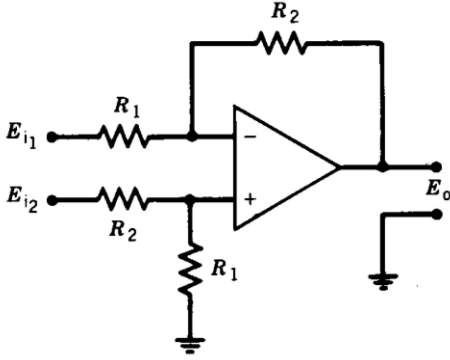
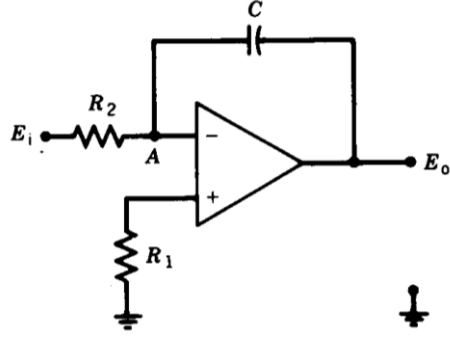
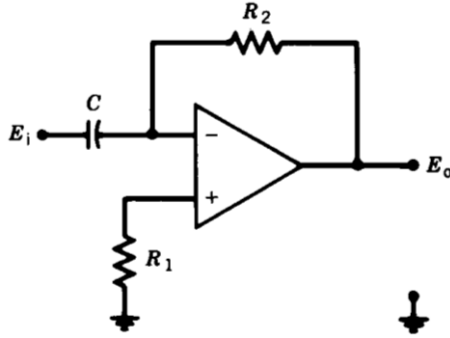
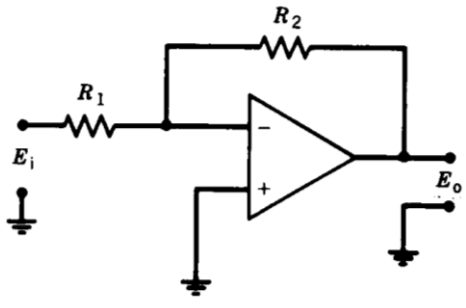
 <p>30) Figure 6. Op-Amp Circuit is a:</p>	 <p>31) Figure 7. Op-Amp Circuit is a:</p>
 <p>32) Figure 8. Op-Amp Circuit is a:</p>	 <p>33) Figure 9. Op-Amp Circuit is a:</p>
 <p>34) Figure 10. Op-Amp Circuit is a:</p>	<p>35) The gain of the amplifier circuit in Figure 10 is</p> <ul style="list-style-type: none"> a) $-R_1R_2$ b) $-R_1/R_2$ c) R_1R_2 d) R_2/R_1 e) $-R_2/R_1$

36) To avoid loading errors of an effort variable the input resistance of the measuring meter

- a) should be about the same as the sensor output resistance.
- b) should be much less than the sensor output resistance.
- c) should be much greater than the sensor output resistance.

37) To avoid loading error when measuring voltage the input impedance of the measurement instrument should be much greater than the output impedance of the sensor.

- a) true
- b) false

- 38) Temperature should be measured with a high input impedance sensor.
- true
 - false
- 39) Heat Flux is
- an effort variable
 - a flow variable
- 40) Heat flux should be measured with a high input impedance sensor.
- true
 - false
- 41) Given a thermocouple with a time constant of 5 seconds like the one used in lab #2, what is the highest frequency water temperature fluctuation you could accurately track?
- approximately 0.05 Hz.
 - approximately 1.0 Hz.
 - approximately 5 Hz.
 - approximately 5/3 Hz.
- 42) The binary representation of 7 is:
- 0101
 - 1011
 - 0111
 - 1101
 - None of the above

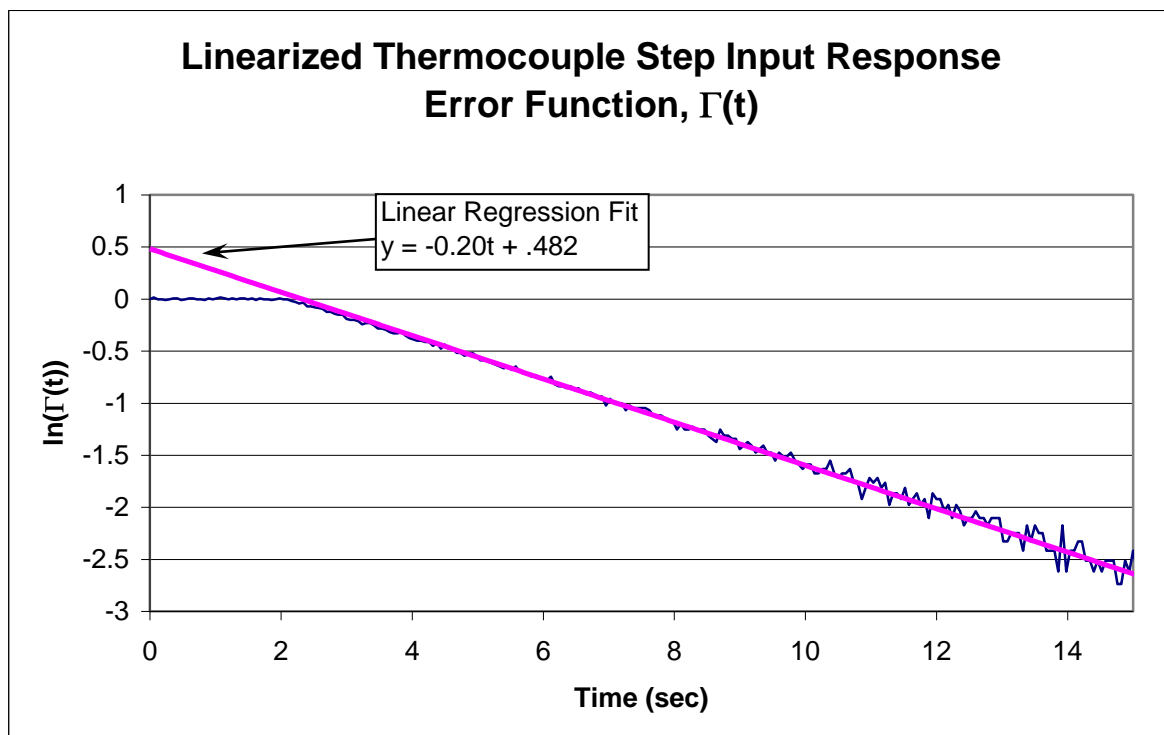

Figure 11. Linearized error function obtained from the dynamic calibration of a thermocouple.

43) The 4 bit 2's complement representation of -3 is:

- a) 1101
- b) 0010
- c) 1111
- d) 1110
- e) None of the above

44) The thermocouple time constant, τ , whose error function is plotted in Figure 11 is approximately:

- a) 2
- b) 5 seconds
- c) 12 seconds
- d) 15 seconds
- e) 20 seconds

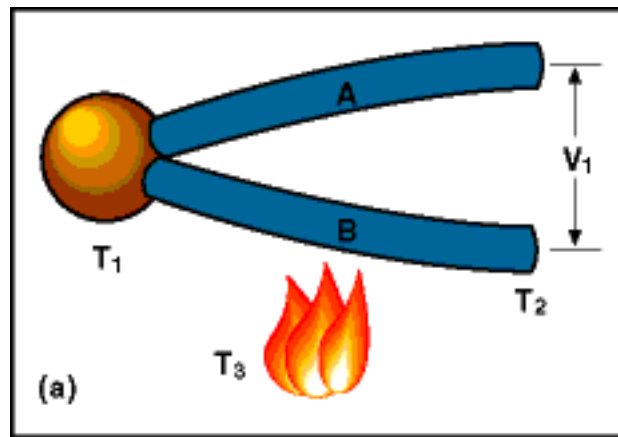

Figure 12. A typical thermocouple diagram

45) The thermocouple in Figure 12 could be used to measure the temperature difference between T_1 and T_2 only if the wires, A & B, were both at the same temperature, T_3 .

- a) True
- b) False

46) The equation, $T(t) = T_\infty + (T_0 - T_\infty)e^{-t/\tau}$, can be used to describe the response of the thermocouple used in lab 2 to a step input change in temperature from T_0 to T_∞ .

- a) True
- b) False

47) The time constant, τ , of a thermocouple is a function of the following factors?

- the specific heat of the thermocouple
- the heat transfer coefficient
- the mass of the thermocouple
- the amplitude of the temperature fluctuations
- the frequency of the temperature fluctuations

- a) True
- b) False

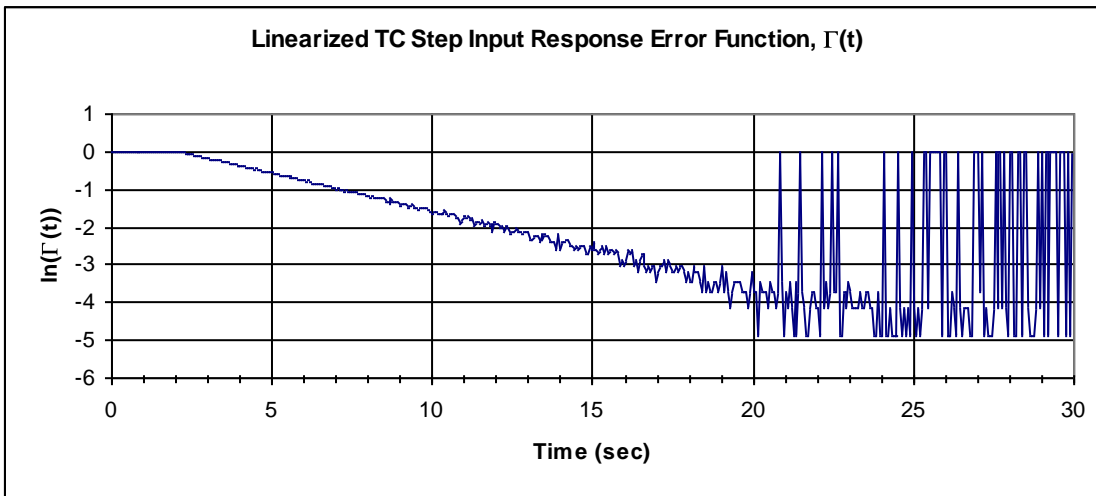

Figure 13. Linearized step input response error function.

48) If your plot of the linearized error function of the dynamic calibration data taken during lab 2 looked like Figure 13 you would obtain a poor estimate of the time constant.

- a) True
- b) False

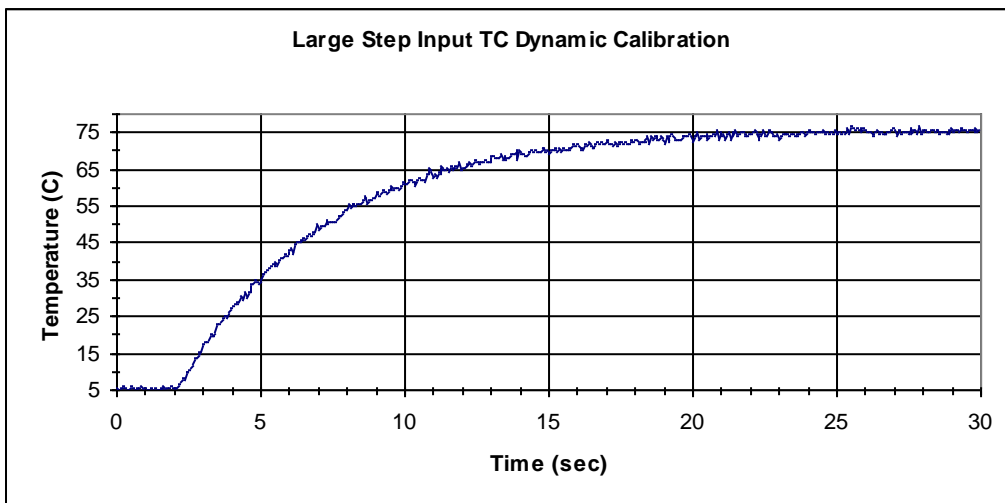

Figure 14. A dynamic recording of a thermocouple subjected to a step input change in temperature.

49) From the thermocouple output plotted in Figure 14 find the time constant, τ , in seconds.

- a) 25
- b) 10
- c) 6
- d) 2

50) The magnitude of the step input applied to the thermocouple plotted in Figure 14 is:

- a) 30 °C
- b) 55 °C
- c) 70 °C
- d) 75 °C

- 51) The units of the static sensitivity obtained in lab #2 for the thermocouple are:
- a) none
 - b) Volts/°C
 - c) °C/Volts
 - d) Seconds/°C
 - e) Volts/Seconds
- 52) In lab #3 you assumed that the amount of work done on the calorimeter was $W = (mg)(\pi dn)$ for constant work input. In our lab setup d was:
- a) distance traveled by the drum
 - b) diameter of the drum
 - c) length of the string in contact with the drum
- 53) Because the heat transferred from the drum to the lab air in lab #3 was constant for all the data collected while turning the drum, the change in temperature per unit time, dT/dt , was constant for all runs.
- a) True
 - b) False
- 54) Given a second order system with a damping ratio of 0.5, a reduction in the mass of the system will cause it to oscillate at a higher frequency.
- a) True
 - b) False
- 55) Given a second order system with a damping ratio of 0.5, a reduction in the mass of the system will reduce the settling time.
- a) True
 - b) False
- 56) Given a second order system with a mass of 1 gram, lowering the damping ratio to 0.1 from 0.707 will cause the system to settle faster.
- a) True
 - b) False
- 57) Given a second order system with a mass of 1 gram, increasing the damping ratio from 1 to 2 shorten the settling time of the system.
- a) True
 - b) False
- 58) A diaphragm type pressure transducer should be modeled as a second order system.
- a) True
 - b) False

slope	23502	16.400	intercept
Standard error for the slope	110.32	0.1242	Standard error for the intercept
R Square	0.9991	0.7225	S_{y_x} , Standard error for the y estimate
The F statistic	45381	43	v, Degrees of freedom
regression sum of squares	23686	22.44	D, residual sum of squares

Table 1. Microsoft Excel LINEST output from a thermocouple static calibration data set.

59) Using the output from the LINEST function in Table 1 determine the 95% confidence interval of the fit.

- $y_{ci} = \pm (0.9991)(2.017)$
- $y_{ci} = \pm (0.7225)(2.017)$
- $y_{ci} = \pm (16.4)(2.017)$
- $y_{ci} = \pm (0.1242)(2.017)$
- none of the above

60) More than 99.9% of the variance in y is accounted for by the fit in Table 1.

- True
- False

61) The static sensitivity of the thermocouple fit in Table 1 is

- 23,502 volts/°C
- 23,502 °C/volt
- 23,502 (no units)

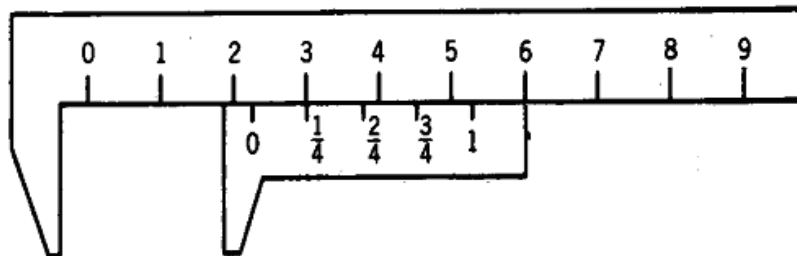

62) The reading of the vernier scale in the figure above is

- 2
- 2.25
- 2.5
- 2.75
- 3

63) In lab #4 you used different pressure step sizes to estimate the dynamic response characteristics of the pressure system. Which of these characteristics depends on the size the step?

- Settling time
- Rise time
- Natural frequency of the transducer (ω_n)
- both a) & b)
- none of the above

- 64) The damped oscillating frequency, ω_d , of the pressure transducer system tested in lab #4 was found to be approximately
- 30 Hz
 - 300 Hz
 - 3,000 Hz
 - 10,000 Hz
 - 15,000 Hz
- 65) If the damping ratio, ξ , of your car's suspension system was less than 0.25 your shock absorbers should be replaced.
- True
 - False

FIGURE 3.13 Second-order system response to a step function input.

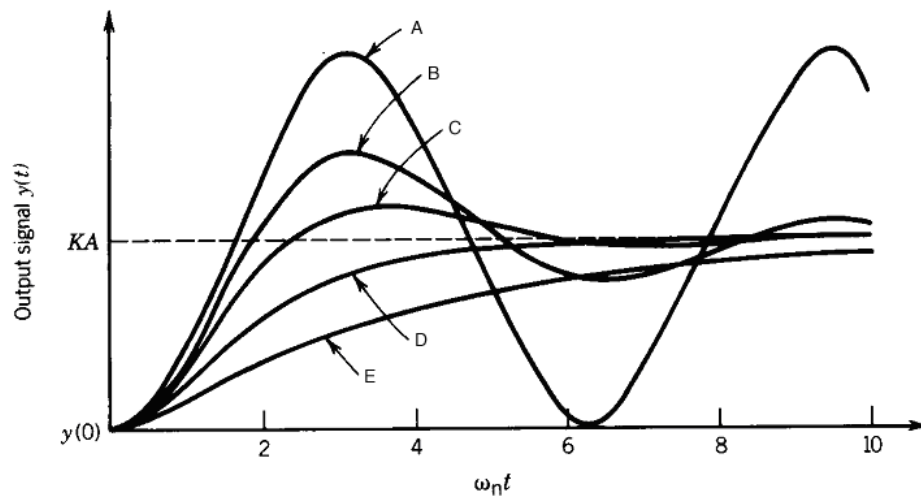

- 66) In the figure above (Figure 3.13 from your text) which curve has the smallest damping ratio, ξ .
- 67) In the figure above (Figure 3.13 from your text) which curve has the largest damping ratio, ξ .
- 68) The input impedance of a deflection device such as a diaphragm pressure transducer is inversely proportional to static sensitivity.
- True
 - False

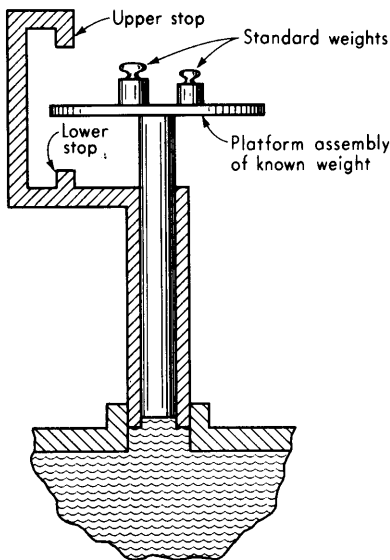

Figure 15. A dead weight pressure transducer assembly diagram.

69) The dead weight pressure transducer illustrated in Figure 15 is a null device.

- a) True
- b) False

70) If you were asked to accurately measure the dynamic pressure exerted during a 1/25 of a second saltwater crocodile bite produced in a hydraulic powered model you would prefer a transducer with a damped natural frequency of

- a) 1/25 Hz
- b) 25 Hz
- c) 50 Hz
- d) 2500 Hz



71) If a saltwater crocodile is capable of producing 4000 lbs of jaw muscle closing force and your available 5000 PSI transducer has a static sensitivity of 5000 lbs/5 volts how would you set up your 10 volt full scale range ADC?

- a) bi-polar, gain = 1
- b) uni-polar, gain = 1
- c) bi-polar, gain = 2
- d) uni-polar, gain = 2

72) A histogram of a thorough static calibration data set would

- a) provides an indication of the instrument precision error.
- b) should be normally distributed.
- c) should be evenly distributed.
- d) both A and B are correct.

- 73) An electrical potentiometer exhibits dynamic behavior typical of a:
- zeroth order system.
 - first order system.
 - second order system.
- 74) The area under the delta function, $\delta(0)$, is 1 by definition.
- true
 - false
- 75) A 53 Hz sine wave sampled at 100 Hz will result in a sampled data set with what frequency
- 3 Hz
 - 53 Hz
 - 100 Hz
 - none of the above
- 76) The quantization size of an ADC is related to:
- the speed of the A/D conversion.
 - the number of bits of the A/D converter.
 - the amplitude of the input signal relative to the full range of the A/D converter.
 - all of the above are correct.
 - only B and C are correct.
- 77) Accuracy is a measure of the ability to represent a true (known) value.
- true
 - false
- 78) The width of the probability density function is proportional to the standard deviation of a normally distributed variable.
- true
 - false
- 79) The standard deviation is the square of the variance.
- true
 - false
- 80) The lowest resolvable frequency of a data set is
- $(\text{record length})^{-1}$
 - $(\text{record length})/(\text{number of data points})$
 - $(\text{sampling frequency}) * (\text{number of data points})$
 - sampling frequency

For the next 3 questions: Given an analog speedometer with a resolution of 5 mph and an accuracy of $\pm 4\%$ of the reading.

- 81) Find the zero order uncertainty, u_0 , at 60 mph.
- $u_0 = \pm 5$ mph
 - $u_0 = \pm 2.5$ mph
 - $u_0 = \pm 2.4$ mph
 - $u_0 = \pm 1.2$ mph

82) Find the uncertainty error, u_c , at 60 mph

- a) $u_c = \pm 5$ mph
- b) $u_c = \pm 2.5$ mph
- c) $u_c = \pm 2.4$ mph
- d) $u_c = \pm 1.2$ mph

83) The design stage uncertainty, u_d , at 60 mph can be found using the formula

- a) $u_d = \pm (u_c + u_0)^{0.5}$
- b) $u_d = \pm 1/2(u_c + u_0)^{0.5}$
- c) $u_d = \pm (u_c^2 + u_0^2)^{0.5}$
- d) $u_d = \pm 1/2(u_c^2 + u_0^2)^{0.5}$

84) In lab 2, given the ADC used in our lab, what is the zero order uncertainty, u_0 , expressed in terms of temperature in °C. The full scale range of the ADC is, FSR volts, the gain is, G , the static sensitivity of the thermocouple is, K °C/volt.

- a) $u_0 = \pm \frac{1}{2} (\text{FSR } K \text{ } G)/2^{12}$
- b) $u_0 = \pm \frac{1}{2} (\text{FSR } K)/(G 2^{12})$
- c) $u_0 = \pm (\text{FSR } K)/(G 2^{12})$
- d) $u_0 = \pm (\frac{1}{2}(\text{FSR } K)/(G 2^{12}))^{0.5}$

85) A data set containing N samples has a sample mean of $\bar{y} = \frac{1}{N} \sum_{i=1}^N y_i$

- a) true
- b) false

86) Careful calibration of an instrument

- a) requires an accurate calibration reference input.
- b) should cover the entire range of the data to be collected.
- c) can correct for bias error.
- d) all of the above are correct.
- e) only A and C are correct.

87) The quantization error in a data set could be reduced by first

- a) increasing the gain of the input signal.
- b) decreasing the number of bits in the ADC
- c) sampling at a higher frequency
- d) both A and C are correct.
- e) A, B and C are all correct.

88) Given a data set with 30 degrees of freedom, a sample mean of 2.0 and a sample standard deviation of 0.2. Approximately 99% of the data points will lie in the range of

- a) 1.0 to 3.0
- b) 1.45 to 2.55
- c) 1.59 to 2.41
- d) none of the above

- 89) Given a calibration data set with 20 points being fit with the equation, $y_c = a_0 + a_1 \log(xa_2 + a_3)$, how many degrees of freedom are there in the fit?
- 16
 - 17
 - 18
 - 19
 - 20
- 90) If the precision error in a measurement is limited by instrument resolution, the effect of this error can be reduced by
- increasing the gain of the input signal.
 - repeating the measurement several times and averaging the results.
 - both A and B are correct.
 - neither A or B are correct.
- 91) As the standard error of the fit, S_{xy} , decreases the confidence limits on a linear regression line will decrease in magnitude as well.
- True
 - False
- 92) A least squares minimization of the error in a regression analysis minimizes the square of the sum of the differences between the measured and calculated dependent variable for each value of the independent variable.
- True
 - False

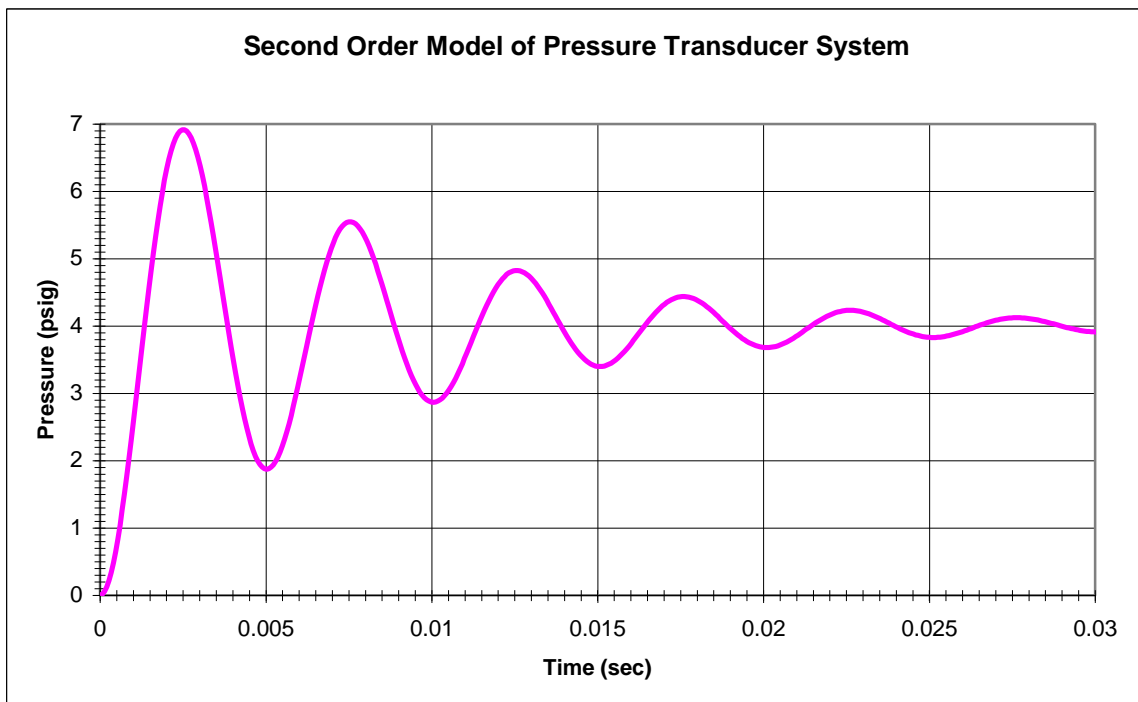

Figure 16. A sample unit step response function of a second order system.

- 93) Figure 16 The damped resonance frequency, ω_d , of the pressure transducer system plotted in Figure 16 is
- 1/0.005 Hz
 - 0.005 Hz
 - 0.0025 Hz
 - 1/0.0025 Hz
- 94) The value of the rise time of the pressure transducer system plotted in Figure 16 is approximately 0.0025 seconds.
- True
 - False
- 95) The value of the settling time of the pressure transducer system plotted in Figure 16 is greater than 0.3 seconds.
- True
 - False
- 96) The lab ambient temperature would be considered an extraneous variable in lab #2.
- True
 - False
- 97) To minimize the effect of extraneous variables during the static calibration of a thermocouple one would like to:
- vary the independent variable in a random order
 - repeat the calibration several times
 - check the calibration result using a different method
 - all of the above
 - only a) and b) are correct
- 98) If an anemometer (air flow meter) calibration produces the relationship, $y = a_0 + a_1V^{0.5}$, where y is the output in meters/second and V is the recorded voltage, then the static sensitivity is constant.
- True
 - False

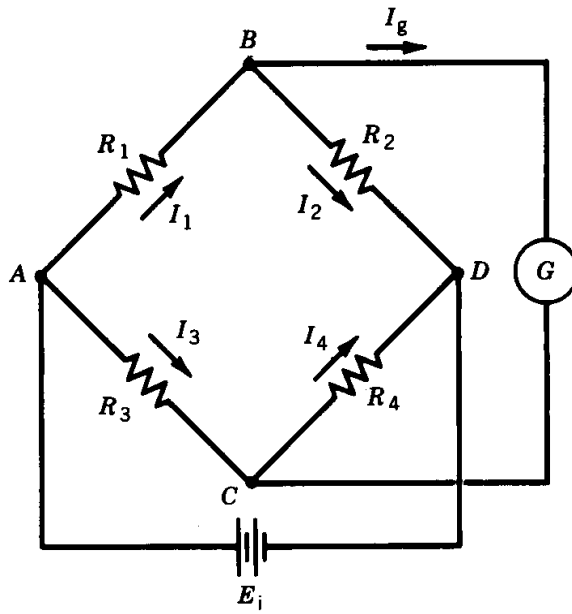

Figure 17. Basic Wheatstone bridge circuit.

- 99) Using the Wheatstone bridge circuit in Figure 17. If R_3 is strain gauge sensor then R_4 could be varied to balance the bridge.
- a) True
 - b) False

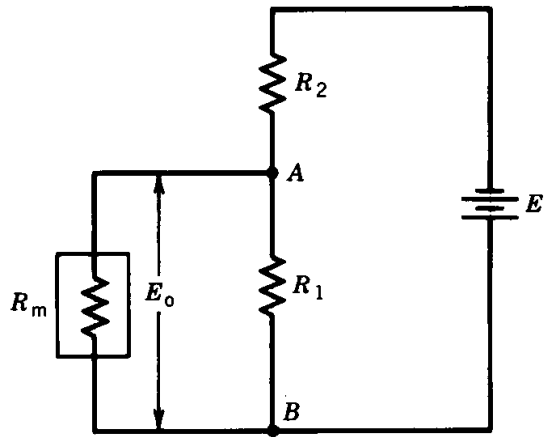

Figure 18. Instruments in parallel to a signal, E_o , form an equivalent voltage dividing circuit.

- 100) If the meter resistance, R_m , is equal to the instrument resistance, R_I , the loading errors will not exceed a few percent.
- a) True
 - b) False

Representative values of the Student-t estimator are as follows:

v	$t_{v, 50\%}$	$t_{v, 90\%}$	$t_{v, 95\%}$	$t_{v, 99\%}$
15	0.691	1.753	2.131	2.947
16	0.690	1.746	2.120	2.921
17	0.689	1.740	2.110	2.898
18	0.688	1.734	2.101	2.878
19	0.688	1.729	2.093	2.861
20	0.687	1.725	2.086	2.845
21	0.686	1.721	2.080	2.831
22	0.686	1.717	2.074	2.819
23	0.685	1.714	2.069	2.807
24	0.685	1.711	2.064	2.797
25	0.684	1.708	2.060	2.787
26	0.684	1.706	2.056	2.779
27	0.684	1.703	2.052	2.771
28	0.683	1.701	2.048	2.763
29	0.683	1.699	2.045	2.756
30	0.683	1.697	2.042	2.750
31	0.682	1.696	2.040	2.744
32	0.682	1.694	2.037	2.738
33	0.682	1.692	2.035	2.733
34	0.682	1.691	2.032	2.728
35	0.682	1.690	2.030	2.724
36	0.681	1.688	2.028	2.719
37	0.681	1.687	2.026	2.715
38	0.681	1.686	2.024	2.712
39	0.681	1.685	2.023	2.708
40	0.681	1.684	2.021	2.704
41	0.681	1.683	2.020	2.701
42	0.680	1.682	2.018	2.698
43	0.680	1.681	2.017	2.695
44	0.680	1.680	2.015	2.692
45	0.680	1.679	2.014	2.690
46	0.680	1.679	2.013	2.687
47	0.680	1.678	2.012	2.685
48	0.680	1.677	2.011	2.682
49	0.680	1.677	2.010	2.680
50	0.679	1.676	2.009	2.678